

DEMAG 250 T

Moving platen

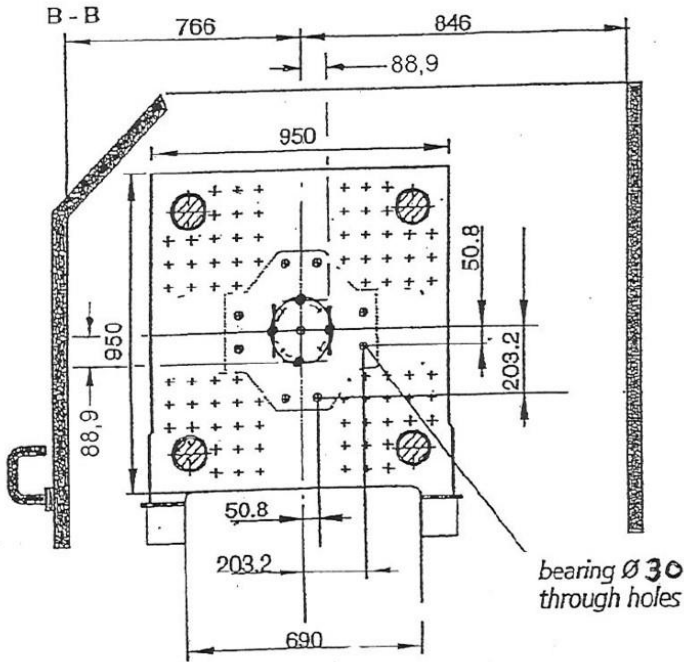

Fixed platen

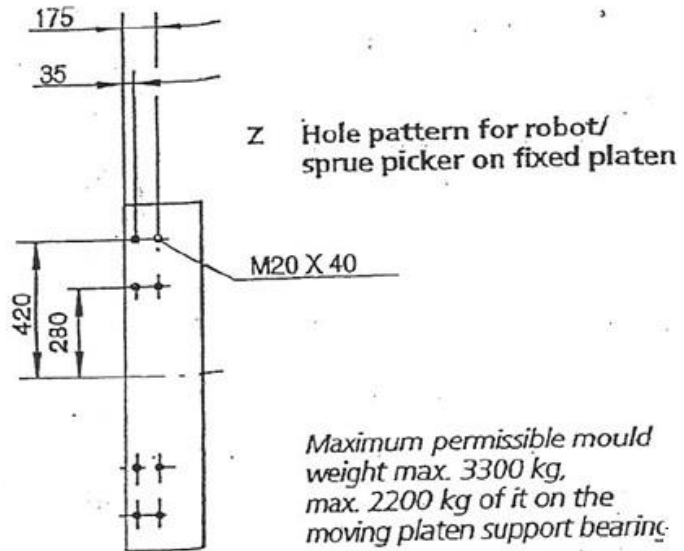
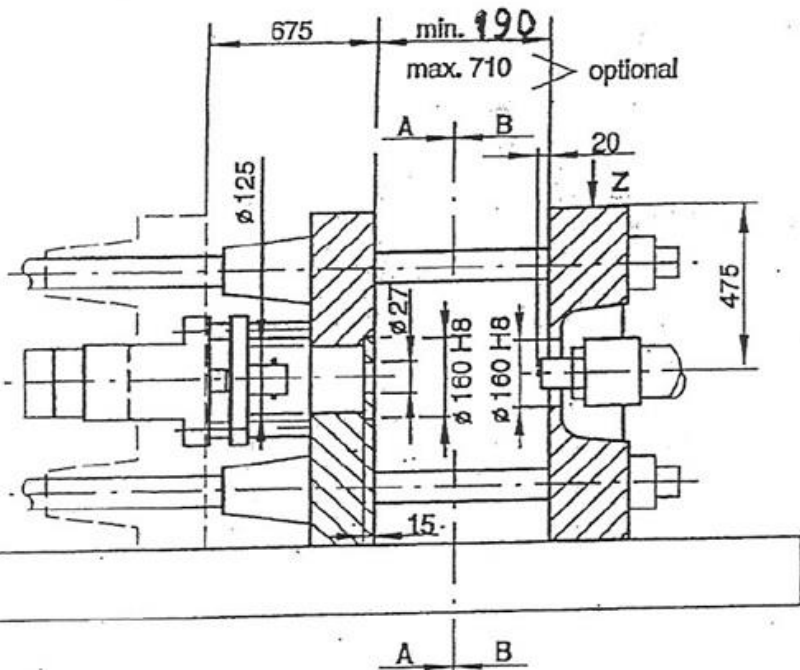
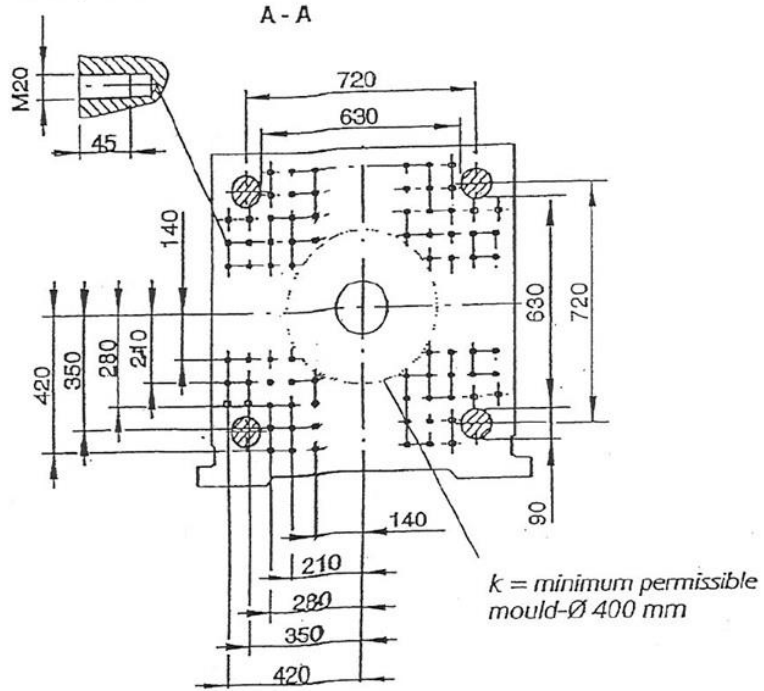

Maximum permissible mould weight max. 3300 kg, max. 2200 kg of it on the moving platen support bearing.